

## DESIGN FEATURES

- Built-in ISO 5211 Direct Mounting Pad Easy Automation
- Fire Safe Design Approved
- Anti-static Devices for Ball-Stem-Body
- Blow-out Proof Stem
- Pressure Balance Hole in Ball Slot
- TA-Luft/ ISO 15848-1 Design Approved
- NACE standard MR0175 & MR0103 (Optional)
- Casting Approved by TÜV AD 2000-Merkblatt W0
- Options:1.Actuator 2.Limit Switch 3.Positioner

## APPLICABLE STANDARDS

- Design Standard : EN 12516-1
- Frie Design : API 607 5<sup>th</sup> 2005, ISO10497
- Flanged Ends : EN 1092-1 PN10-40
- Inspection & Testing : EN 12266-1



## TORQUE VALUES

Close to Open Torque at Various Differential Pressure ( $\Delta P$ ),  
Standard Seats (TFM1600 & PTFE)

Size\ΔP	75 psig		150 psig		240 psig / 300 psig		600 psig	
	5 bar		10 bar		20 bar		50 bar	
DN	N·m	In·lb	N·m	In·lb	N·m	In·lb	N·m	In·lb
15	5	44	5	44	5	44	5	44
20	6	53	6	53	6	53	6	53
25	10	88	10	88	11	97	11	97
32	13	115	13	115	15	133	17	150
40	19	168	19	168	22	195	24	212
50	25	221	29	257	32	283	34	301
65	40	354	45	398	49	434	52	460
80	65	575	72	637	81	717	88	779
100	100	885	110	973	122	1080	132	1168
125	190	1681	210	1858	245	2168	280	2478
150	280	2478	306	2708	340	3009	510	4514

## CV VALUES / WEIGHT

DN	CV	Weight (kg)	
		PN16	PN40
15	30	1.35	
20	55	1.76	
25	96	2.34	
32	170	3.85	
40	270	4.83	
50	470	6.68	
65	780	9.98	10.7
80	1150	—	14.6
100	1800	22.7	27.0
125	3000	34.2	40.5
150	4500	50.6	51.3

Remark :

- 1.Torques will increase about 30% if seat materials are Reinforced Fiber-Glass PTFE,Carbon-filled PTFE or EK+PTFE or TFM4215.
- 2.The torque figures at 5 bar pressure are maximum values to be tested after the valves are placed for 24 hours.
- 3.For actuator sizing, a safety factor of minimum 30% is recommended.

**TECHNICAL INFORMATION**



**PRESSURE - TEMPERATURE DATA**

The pressure-temperature data of ball valves is determined not only by valve shell materials but also by sealing materials used for ball seats, gland packings and flange gaskets.

Full Bore: DN15 to DN25

Full Bore: DN32 to DN65

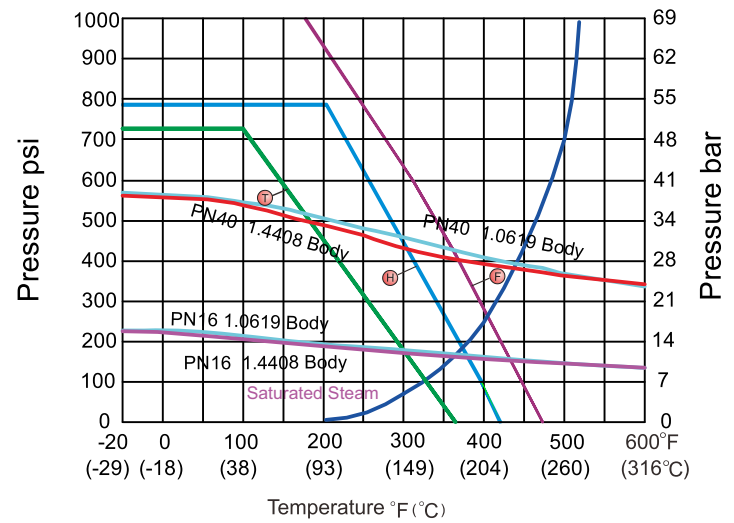
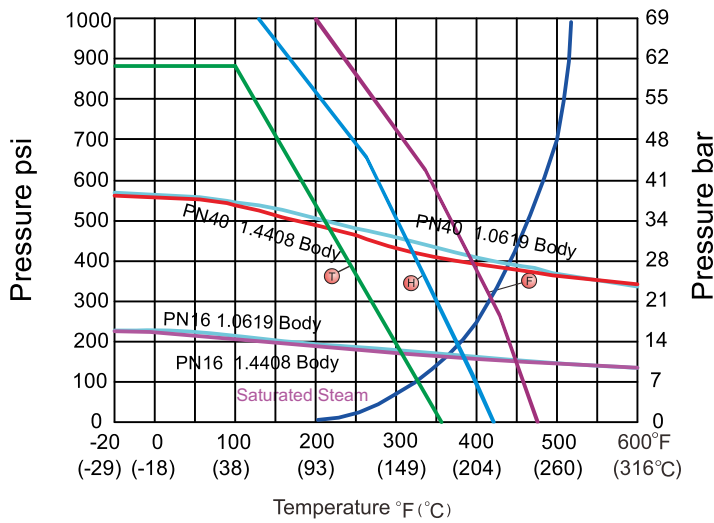

Full Bore: DN80 & DN100

Full Bore: DN125 & DN150

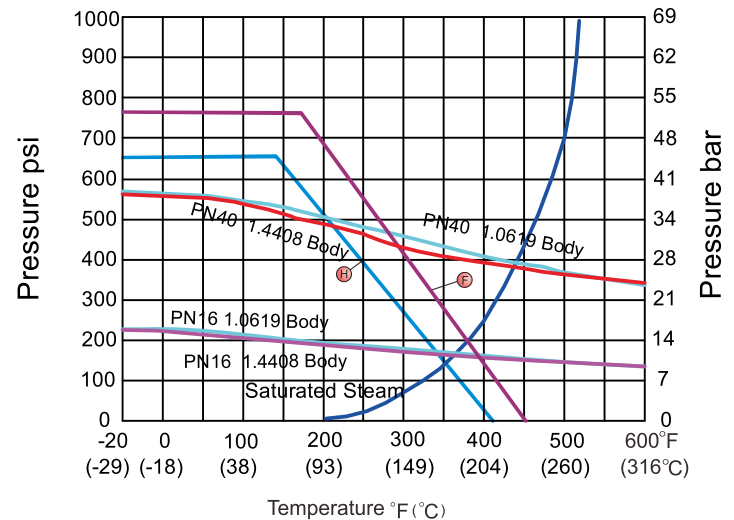
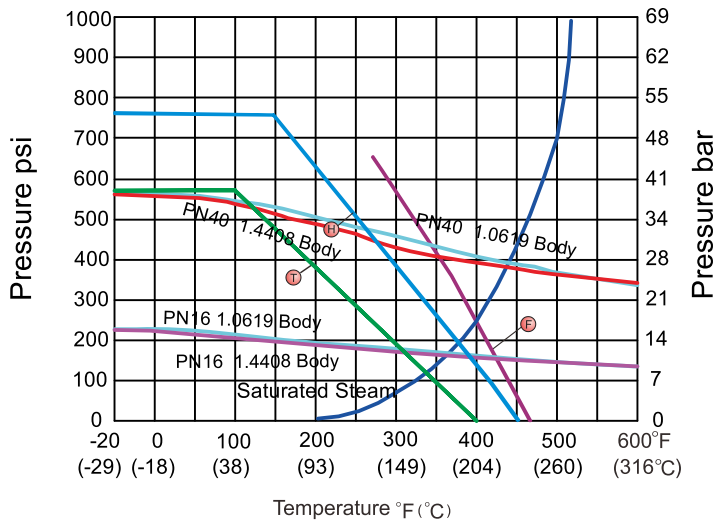

Seat Materials : ● PTFE ● TFM1600 ● TFM4215

Body Ratings: Shown above are for EN10213 Nr. 1.4408 and EN 10213 Nr. 1.0619

For ratings of other valve shell materials, please refer to the last edition of EN12516-1.

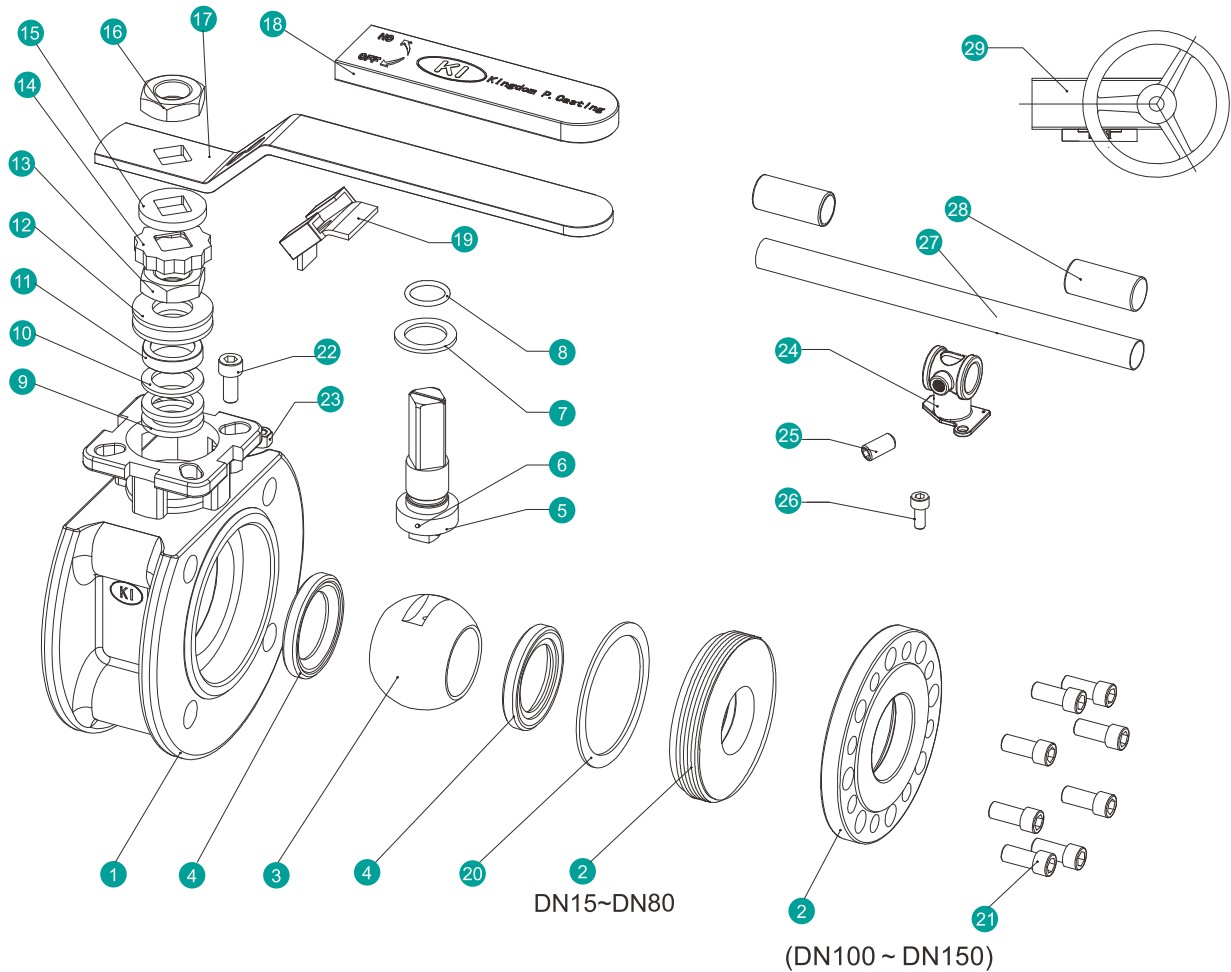

**MATERIAL OF CONSTRUCTION**

NO.	PART NAME	MATERIALS		
1	Body	1.4408	1.4308	1.0619
2	End Cap	1.4408	1.4308	1.0619
3	Ball	316		304
4	Ball Seat		PTFE/TFM1600/TFM4215	
5	Stem	316		304
6	Anti-Static	316		304
7	Thrust Washer		PTFE/TFM1600/RTFE	
8	O-Ring		FKM	
9	Packing		PTFE / GRAPHITE*	
10	Bushing		50%SS+50%PTFE/304*	
11	Gland		316/304	
12	Belleville Washer		301	
13	Stem Nut		A194-8	
14	Stop-lock-Cap		304	
15	Handle Gland	DN15~DN80	304	
16	Handle Nut	DN15~DN80	A194-8	
17	Handle	DN15~DN80	304	
18	Handle Sleeve	DN15~DN80	VINYL PLASTIC	
19	Lock Device	DN15~DN80	304	
20	Body Gasket		PTFE / 316 Spiral Wound+Graphite*	
21	Bolting	DN100~DN150	A2-70	8.8
22	Stop Bolt		A2-70	
23	Stop Nut		A2-70	
24	Handle Adapter	DN100~DN150	A351-CF8	
25	Set Screw	DN100~DN150	A2-70	
26	Bolting	DN100~DN150	A2-70	
27	Pipe Handle	DN100~DN150	A53+PLATED Zn	
28	Handle Sleeve	DN100~DN150	VINYL PLASTIC	
29	Worm Gear	(Optional)	Package	

\*Materials for KV-L7KF, KV-L7NF Series (Fire Safe Models)

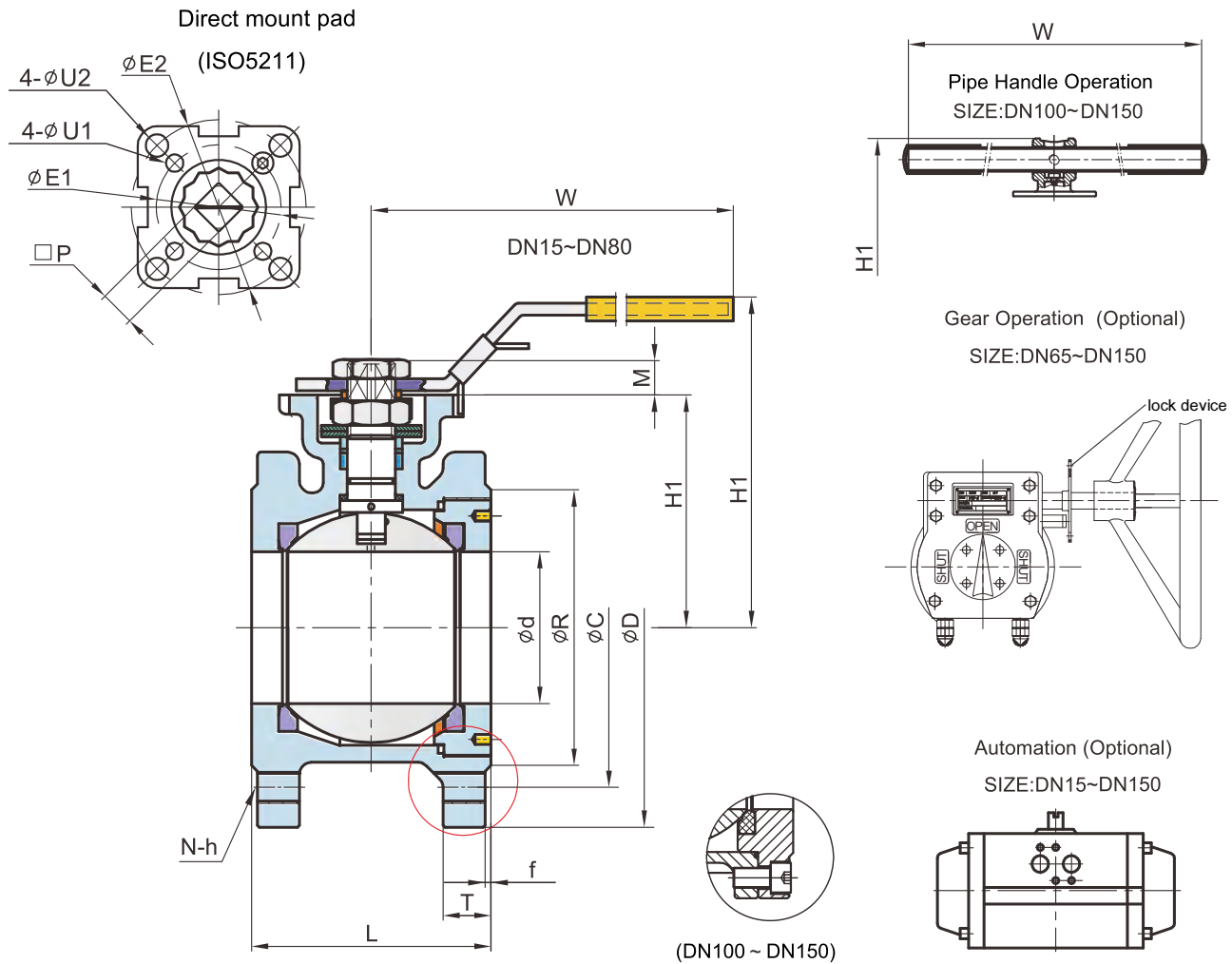

**DIMENSION TABLE**

**EN PN10/16/25/40 DIMENSION TABLE**

Unit: mm

DN	PN	d	R	C	D	f	T	L	H1	W	H	M	P	N	h	U1	U2	E1	E2	ISO 5211
15	10	15.0	45	65	95	2	9	42	78	147	48	9	9	4	M12	6	6	36	42	F03-F04
20		20.0	58	75	105	2	9	44	85	147	54	9	9	4	M12	6	6	36	42	F03-F04
25	16	25.0	68	85	115	2	9	50	94	177	62	11	11	4	M12	6	7	42	50	F04-F05
32		32.0	78	100	140	2	12	60	104	177	72	11	11	4	M16	6	7	42	50	F04-F05
40	40	38.0	88	110	150	3	13	65	114	197	78	14	14	4	M16	7	9	50	70	F05-F07
50		50.0	102	125	165	3	20	80	120	197	86	14	14	4	M16	7	9	50	70	F05-F07
65	10/16	63.5	122	145	185	3	18	110	158	267	108	17	17	4	M16	9	11	70	102	F07-F10
	22						113													
80	10/16	76.0	138	160	200	3	20	120	165	267	116	17	17	8	M16	9	11	70	102	F07-F10
	24						154													
100	10/16	95.0	158	180	220	3	20	150	212	400	140	22	22	8	M16	N/A	11	N/A	102	F10
	M20		154																	
125	10/16	118.0	188	210	250	3	22	180	255	600	175	27	27	8	M16	N/A	14	N/A	125	F12
	M24			226																
150	10/16	142.0	212	240	285	3	22	225	275	800	195	27	27	8	M20	N/A	14	N/A	125	F12
	M24		228																	

**KV-L7K, KV-L7KF—PN16**

**KV-L7N, KV-L7NF—PN40**